

**FANUC**

# **ROBOTS**

## **PRODUCT OVERVIEW**



# FANUC

## ROBOTS

### PRODUCT OVERVIEW

---

#### Application Icon Key



**Assembly**



**ARC Welding**



**Spot Welding**



**Pick/Pack/  
Palletizing**



**Load/Transfer**



**Material  
Removal**



**Dispensing**



**Painting/  
Coating**

# LR Mate Series



ER-4iA LR Mate 200iD	Max. Payload (kg)	Reach (mm)	Mass (kg)	Axes	Floor	Angle	Invert
ER-4iA	4	550	20	6	✓		✓
LR Mate 200iD/4S	4	550	20	6	✓	✓	✓
LR Mate 200iD/4SH	4	550	19	5	✓	✓	✓
LR Mate 200iD/4SC	4	550	20	6	✓	✓	✓
★ LR Mate 200iD	7	717	25	6	✓	✓	✓
LR Mate 200iD/7H	7	717	24	5	✓	✓	✓
LR Mate 200iD/7C	7	717	25	6	✓	✓	✓
LR Mate 200iD/7WP	7	717	25	6	✓	✓	✓
LR Mate 200iD/7L	7	911	27	6	✓	✓	✓
LR Mate 200iD/7LC	7	911	27	6	✓	✓	✓
LR Mate 200iD/14L	14	911 (820)	27	6	✓	✓	✓

() For LR Mate 200iD/14L, 911mm reach is available when load capacity is <12kg



★ **Featured Model**  
**LR Mate 200iD**

# M-10 Series



M-10iD	Max. Payload (kg)	Reach (mm)	Mass (kg)	Axes	Floor	Angle	Invert
M-10iD/8L	8	2032	180	6	✓	✓	✓
M-10iD/10L	10	1636	150	6	✓	✓	✓
★ M-10iD/12	12	1441	145	6	✓	✓	✓
M-10iD/16S	16	1103	140	6	✓	✓	✓



## Feature Spotlight: M-10iD/12

FANUC M-10iD/12 offers the highest speed and precision in its class. A sleek and lightweight design features internal cable routing and a curved J2 arm minimizing interference with work pieces and fixtures, and maximizing productivity. The robot has a long reach and stroke - including the backflip region - making it easy to apply even in tight workspaces.

★ **Featured Model**  
M-10iD/12

# M-20 Series



M-20iB M-20iD	Max. Payload (kg)	Reach (mm)	Mass (kg)	Axes	Floor	Angle	Invert
M-20iB/25	25	1853	210	6	✓	✓	✓
★ M-20iB/25C	25	1853	210	6	✓	✓	✓
M-20iB/35S	35	1445	205	6	✓	✓	✓
M-20iD/12L	12	2272	250	6	✓	✓	✓
M-20iD/25	25	1831	250	6	✓	✓	✓
M-20iD/35	35	1831	250	6	✓	✓	✓



## Feature Spotlight: M-20iB/25C

A six-axis robot for handling products in a wide range of industries, including cleanroom environments. It offers a rigid and compact design with a sealed structure (integrated utilities and motors), and a rear or bottom exit for cables. The entire robot is rated IP67, allowing it to withstand harsh environments.

★ **Featured Model**  
**M-20iB/25C**

# M-410 Series

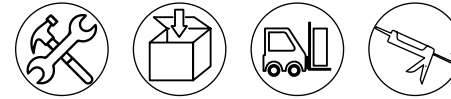

M-410iB M-410iC	Max. Payload (kg)	Reach (mm)	Mass (kg)	Axes	Floor Angle	Invert
M-410iB/140H	140	2850	1200	5	✓	
M-410iB/700	700	3143	2700	4	✓	
M-410iC/110	110	2403	1030	4	✓	
★ M-410iC/185	185	3143	1600 (1330)	4	✓	
M-410iC/315	315	3143	1600 (1330)	4	✓	
M-410iC/500	500	3143	2410 (1910)	4	✓	

() Without pedestal

## Feature Spotlight: M-410iC/185

This compact four-axis model is designed for high speed palletizing, assembly, machining and parts transfer applications. The increased throughput makes it ideal for high volume production.



★ **Featured Model**  
**M-410iC/185**



# M-710 Series



M-710 <i>i</i> C	Max. Payload (kg)	Reach (mm)	Mass (kg)	Axes	Floor	Angle	Invert
M-710 <i>i</i> C/12L	12	3123	540	6	✓	✓	✓
M-710 <i>i</i> C/20L	20	3110	540	6	✓	✓	✓
M-710 <i>i</i> C/20M	20	2582	530	6	✓	✓	✓
M-710 <i>i</i> C/45M	45	2606	570	6	✓	✓	✓
★ M-710 <i>i</i> C/50	50	2050	560	6	✓	✓	✓
M-710 <i>i</i> C/50E	50	2050	560	6	✓	✓	✓
M-710 <i>i</i> C/50H	50	2003	540	5	✓		✓
M-710 <i>i</i> C/50S	50	1359	545	6	✓	✓	✓
M-710 <i>i</i> C/70	70	2050	560	6	✓	✓	✓

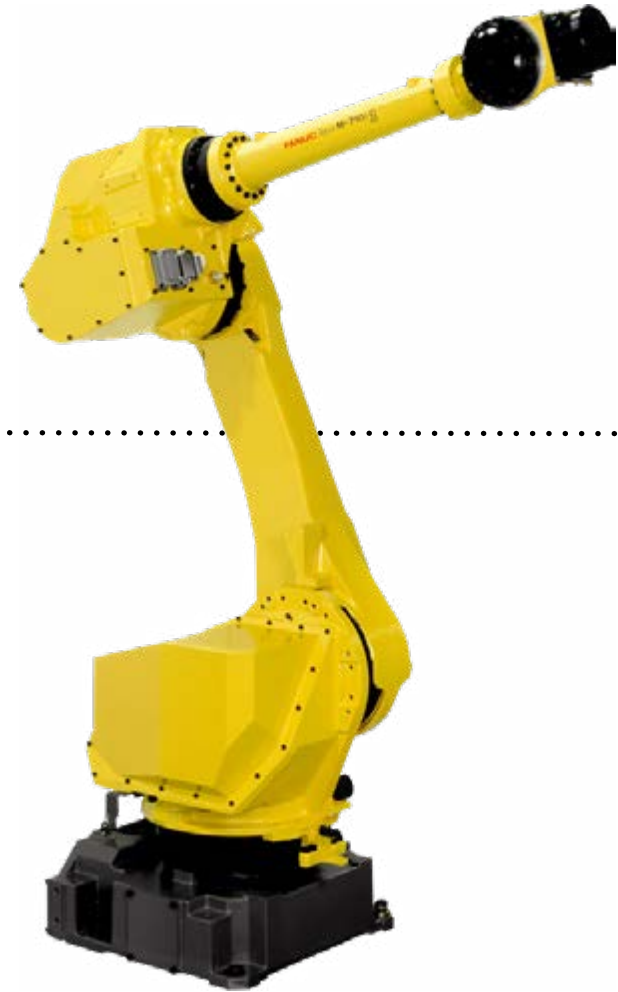

## Feature Spotlight: M-710*i*C/50

This innovative of lightweight robot features a slim wrist, rigid arm and small footprint. High axis speeds combined with huge 6-axis versatility make it the perfect choice for handling awkward payloads. The M-710*i*C/50 has a good balance of payload vs. speed capability.

★ **Featured Model**  
**M-710*i*C/50**

# M-900 Series

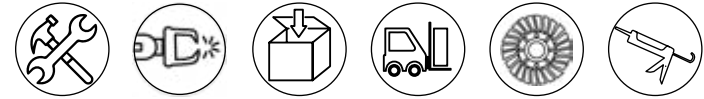

M-900iA M-900iB	Max. Payload (kg)	Reach (mm)	Mass (kg)	Axes	Floor	Angle	Invert
M-900iA/200P	200	3507	2670	6	RACK		
M-900iB/280	280	2655	1700	6	✓	✓	✓
M-900iB/280L	280	3103	1600	6	✓	✓	✓
M-900iB/330L	330	3203	1780	6	✓		
M-900iB/360	360	2655	1540	6	✓	✓	✓
M-900iB/400L	400	3704	3150	6	✓		
M-900iB/700	700	2832	2800	6	✓		

# M-800

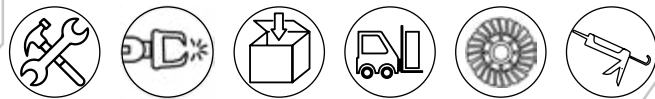

M-800iA	Max. Payload (kg)	Reach (mm)	Mass (kg)	Axes	Floor	Angle	Invert
M-800iA/60	60	2040	820	6	✓		



★ **Featured Model**  
**M-800iA/60**





# M-2000 Series

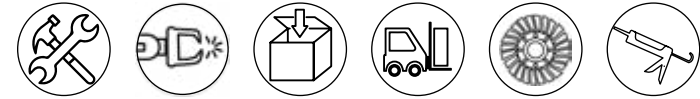

M-2000iA	Max. Payload (kg)	Reach (mm)	Mass (kg)	Axes	Floor	Angle	Invert
M-2000iA/900L	900	4683	9600	6	✓		
M-2000iA/1200	1200 (1350)	3734	8600	6	✓		
M-2000iA/1700L	1700	4683	12500	6	✓		
★ M-2000iA/2300	2300	3734	11000	6	✓		

( ) With hardware and/or software option

## Feature Spotlight: M-2000iA/2300

With its enormous payload of 2.3 metric tons, the M-2000iA/2300 is the biggest lifter in the M-2000 series. Ideally suited to handle material handling applications that require an even stronger wrist, this machine will easily lift and position an entire car or load bulky castings onto machine fixtures.



★ **Featured Model**  
M-2000iA/2300

# R-1000 Series

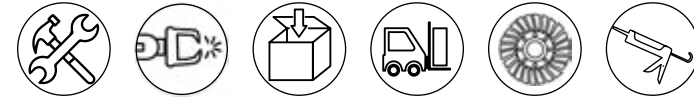

R-1000iA	Max. Payload (kg)	Reach (mm)	Mass (kg)	Axes	Floor	Angle	Invert
R-1000iA/80F	80	2230	620	6	✓		✓
R-1000iA/80H	80	2230	610	5	✓		✓
★ R-1000iA/100F	100	2230	665	6	✓		✓
R-1000iA/120F-7B	120	2230	790	7	✓		✓
R-1000iA/130F	130	2230	675	6	✓		✓



## Feature Spotlight: R-1000iA/100F

FANUC R-1000iA/100F has the inherent flexibility to complete any number of challenging jobs. Very fast and capable of realizing excellent cycle times, it is particularly suited to a wide range of high-speed spot welding applications. Being compact and lightweight, it also saves you space.

★ **Featured Model**  
R-1000iA/100F

# SCARA Series



Robot Model	Max. Payload (kg)	Reach (mm)	Mass (kg)	Axes	Floor	Angle	Invert
SR-3iA	3	400	19	4	✓	✓	
SR-3iA/H	3	400	17	3	✓	✓	
SR-6iA	6	650	30	4	✓	✓	
SR-6iA/H	6	650	28	3	✓	✓	
★ SR-12iA	12	900	53	4	✓	✓	
SR-20iA	20	1100	64	4	✓	✓	



## Feature Spotlight: SR-12iA

To make the most of your floor space, FANUC SCARA robots occupy an ultra-compact footprint and are designed to minimize interference with peripheral devices. The SR-12iA has the payload capacity of 12kg and operates in a 360° envelope.

★ **Featured Model**  
SR-12iA

# Collaborative Series

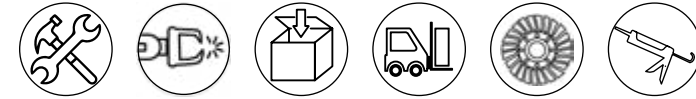

Robot Model	Max. Payload (kg)	Reach (mm)	Mass (kg)	Axes	Floor	Angle	Invert
CR-4iA	4	550	48	6	✓	✓	✓
CR-7iA	7	717	53	6	✓	✓	✓
CR-7iA/L	7	911	55	6	✓	✓	✓
CR-14iA/L	14	911	55	6	✓	✓	✓
CR-15iA	15	1441	255	6	✓	✓	✓
CR-35iA	35	1813	990	6	✓		
CRX-10iA	10	1249*1	40	6	✓	✓	✓
★ CRX-10iA/L	10	1418*1	40	6	✓	✓	✓

\*1) Reach specification from faceplate

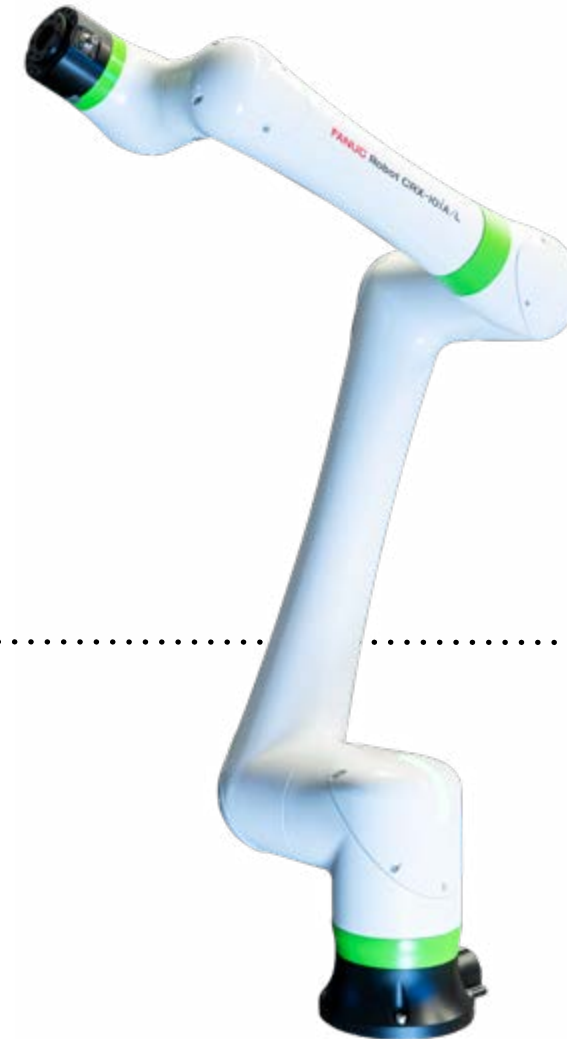

## Feature Spotlight: CRX-10iA/L

Lightweight and compact design allows for quick integration into any work area or existing system. CRX is easy to use and teach points using lead-through programming and a tablet interface with drag-and-drop icons.



**Featured Model**  
CRX-10iA/L

# Paint Series



Robot Model	Max. Payload (kg)	Reach (mm)	Mass (kg)	Axes	Floor	Angle	Invert
Paint Mate 200iA/5L	5	892	37	6	✓	✓	✓
P-40iA	5	1300	110	6	✓	✓	✓
P-50iB/10L	10	1800	364	6	✓	✓	✓
★ P-250iB	15	2800	530	6	✓	✓	✓
P-350iA	45	2606	590	6	✓	✓	✓
P-700iB Plastic Arm	15	3150	658 (S) 665 (L)	7		Rail Mounted	
P-700iB Metal Arm	15	3200	659 (S) 667 (L)	7		Rail Mounted	
P-1000iA Plastic Arm	15	2848	700	7			✓
P-1000iA Metal Arm	15	2896	700	7			✓

(S) Short Arm Version (L) Long Arm Version

## Feature Spotlight: P-250iB

P-250iB is known for excellence in general industry, automotive components, and automotive finishing. This model includes metal or plastic arm options, both having in arm process controls. It has a large handling capacity, generous work envelope and is certified internationally for hazardous environments.



**Featured Model**  
**P-250iB**

# Arc Welding Series



Robot Model	Max. Payload (kg)	Reach (mm)	Mass (kg)	Axes	Floor	Angle	Invert
ARC Mate 50iD/7L	7	911	27	6	✓	✓	✓
ARC Mate 100iD	12	1441	145	6	✓	✓	✓
ARC Mate 100iD/10L	10	1636	150	6	✓	✓	✓
ARC Mate 100iD/8L	8	2032	180	6	✓	✓	✓
<b>★ ARC Mate 120iD</b>	<b>25</b>	<b>1831</b>	<b>250</b>	<b>6</b>	<b>✓</b>	<b>✓</b>	<b>✓</b>
ARC Mate 120iD/12L	12	2272	250	6	✓	✓	✓
M-20iB/25 (For Arc)	25	1853	210	6	✓	✓	✓
M-710iC/12L (For Arc)	12	3123	540	6	✓	✓	✓
CR-7iA/L (For Arc)	7	911	55	6	✓	✓	✓
CRX-10iA (For Arc)	10	1249	40	6	✓	✓	✓
CRX-10iA/L (For Arc)	10	1418	40	6	✓	✓	✓
CR-15iA (For Arc)	15	1441	255	6	✓	✓	✓



**★** **Featured Model**  
**ARC Mate 120iD**



# Top Loader Series

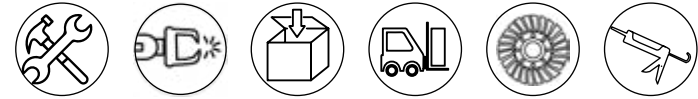

Robot Model	Max. Payload (kg)	Reach (mm)	Mass (kg)	Axes	Rail Mounted
M-20iA/20T	20	1662*4	185	6	
M-20iA/20MT	20	1663*4	185	6	
M-20iA/35MT	35	1663*4	185	6	
★ M-710iC/50T	50	1900*4	410	6	
M-710iC/70T	70	1900*4	410	6	
R-2000iB/200T	200	2208*4	1280	6	

\*4) Depending on rail specification

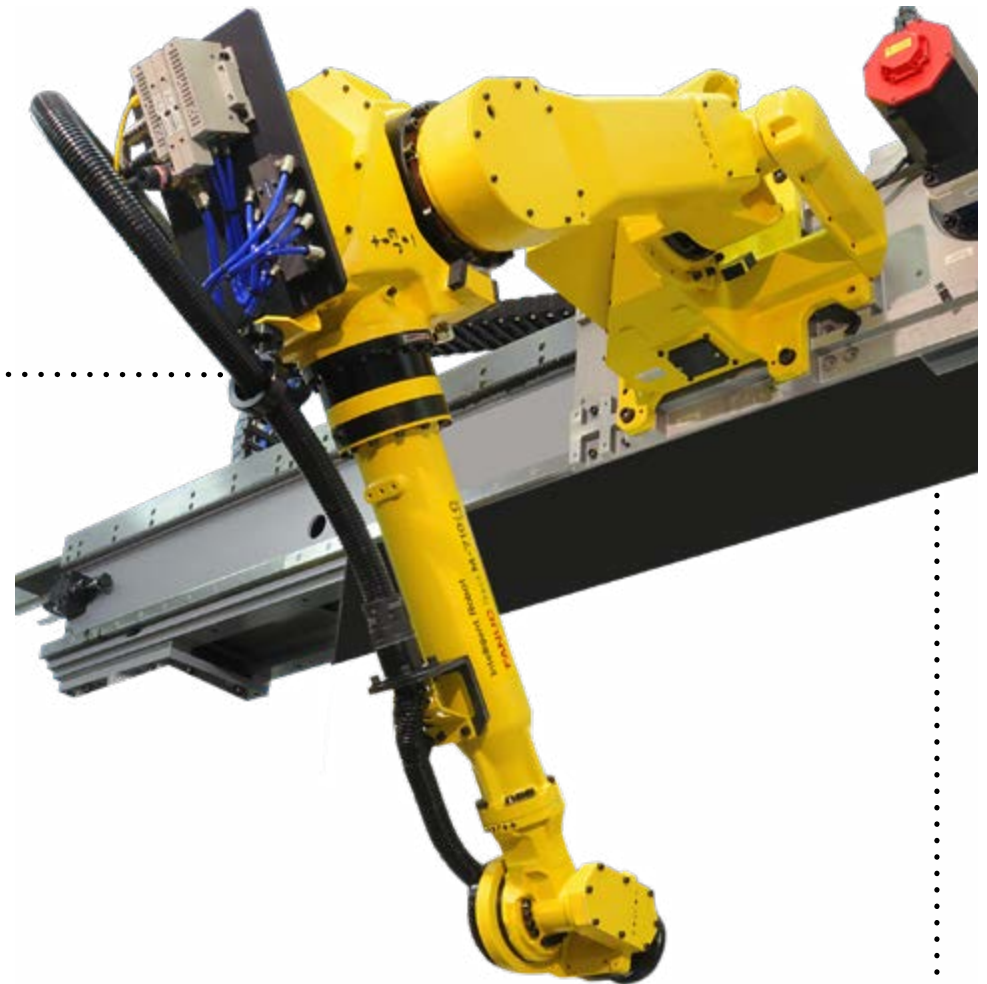

## Feature Spotlight: M-710iC/50T

This innovative and lightweight robot features a slim wrist, rigid arm and small footprint. High axis speeds make it extremely fast, even at payloads of up to 50kg.

★ **Featured Model**  
**M-710iC/50T**

# Delta Series



Robot Model	Max. Payload (kg)	Reach (mm)	Mass (kg)	Axes	Floor	Angle	Invert
<b>DR-3iB/8L</b>	8	1600	170	4	Ceiling		
<b>M-1iA/0.5A</b>	0.5 (1) <sup>*2</sup>	280	23 <sup>*3</sup>	6	✓	✓	✓
<b>M-1iA/0.5AL</b>	0.5 (1) <sup>*2</sup>	420	26 <sup>*3</sup>	6	✓	✓	✓
<b>M-1iA/0.5S</b>	0.5 (1) <sup>*2</sup>	280	20 <sup>*3</sup>	4	✓		✓
<b>M-1iA/0.5SL</b>	0.5 (1) <sup>*2</sup>	420	23 <sup>*3</sup>	4	✓		✓
<b>M-1iA/1H</b>	1	280	18 <sup>*3</sup>	3	✓		✓
<b>M-1iA/1HL</b>	1	420	21 <sup>*3</sup>	3	✓		✓
<b>M-2iA/3S</b>	3	800	130	4			
<b>M-2iA/3SL</b>	3	1130	130	4			
<b>M-2iA/3A</b>	3	800	140	6			
<b>M-2iA/3AL</b>	3	1130	140	6			
<b>M-2iA/6H</b>	6	800	125	3			
<b>M-2iA/6HL</b>	6	1130	125	3			
<b>M-3iA/6S</b>	6 (8) <sup>*2</sup>	1350	160	4			
<b>M-3iA/6A</b>	6	1350	175	6			
<b>M-3iA/12H</b>	12	1350	155	3			

\*2) Optional higher payload \*3) With stand

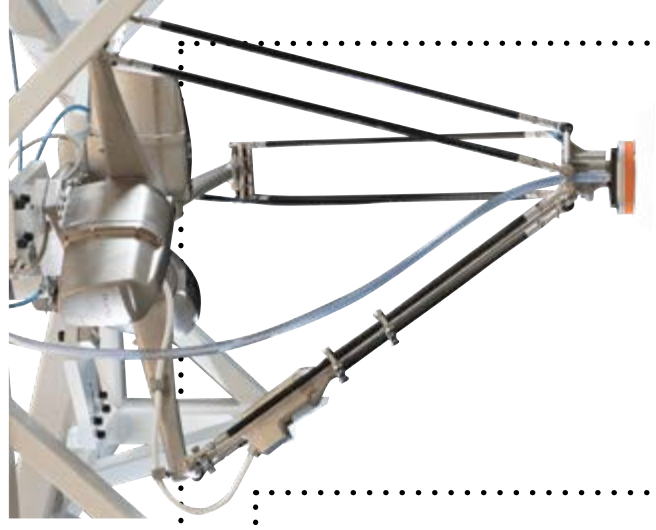

**Featured Model  
DR-3iB/8L**



**Featured Model  
M-1iA/0.5A**

# R-2000 Series



	Max. Payload (kg)	Reach (mm)	Mass (kg)	Axes	Floor	Angle	Invert
R-2000iB R-2000iC R-2000iD	100	2655	1150	5	✓		
R-2000iB/100H	170	1520	800	6	✓		
R-2000iB/170CF	100	3540	1470	6		RACK	
R-2000iC/100P	125	3100	1115	6	✓		
R-2000iC/125L	165	2655	1090	6	✓		
R-2000iC/165F	165	3095	1370	6		RACK	
R-2000iC/190U	190	3100	1400	6			✓
★ R-2000iC/210F	210	2655	1090	6	✓		
R-2000iC/210L	210	3100	1350	6	✓		
R-2000iC/210R	210	3095	1370	6		RACK	
R-2000iC/210WE	210	2450	1180	6	✓		
R-2000iC/220U	220	2518	1020	6			✓
R-2000iC/240F	240	2655	1090	6	✓		
R-2000iC/270F	270	2655	1320	6	✓		
R-2000iC/270R	270	3095	1590	6		RACK	
R-2000iD/165FH	165	2605	1150	6	✓		
R-2000iD/100FH	100	2605	1150	6	✓		
R-2000iD/210FH	210	2605	1150	6	✓		

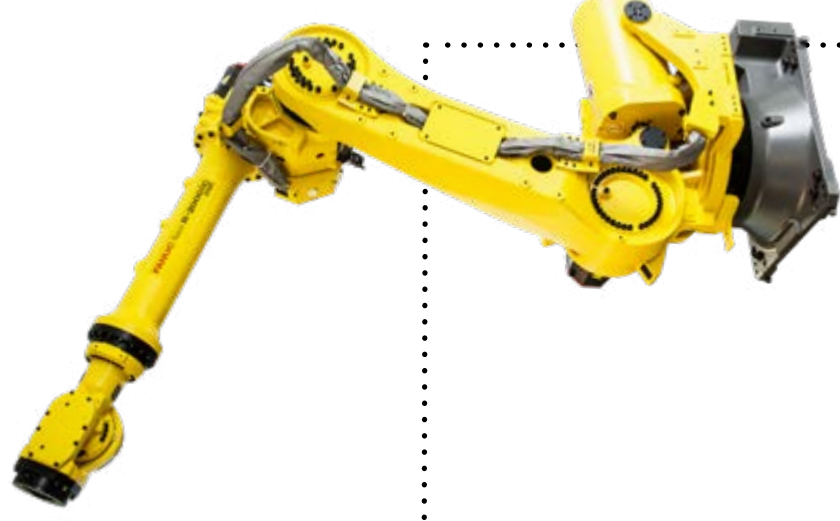

**Featured Model**  
**R-2000iC/210F**