

# MOD-WELD



## ROBOTIC WELDING



COBOT

ARC MATE



**FANUC**



INTEGRATED BY  
**APT**  
MANUFACTURINGsolutions



# MOD-WELD



## TABLE OF CONTENTS

### Why choose MOD-WELD?

- Produce more with the labor you have
- Best industry partners: FANUC, Miller, and Rockwell
- FANUC intelligent options including:
  - iRVision
  - Through-ARC Seam Tracking
  - Touch Sensing
- Double your throughput, quicker to market
- Better accuracy and consistent welds
- Higher productivity and quality
- FANUC “Service First” – Lifetime Support

### MAC Series - Miller/APT/CRX

- Ease of programming with APT Clever Torch
- FANUC CRX cobot
- FANUC CRX “8 Years Zero Maintenance”
- Miller Auto-Continuum™
- Safe for human collaborative interaction
- Quick to deploy and setup

### MATE Series - Miller/APT/ARC Mate

- Rockwell controls
- High volume production
- Ease of use operator interface
- FANUC ARC Mate Series robot
- Miller Auto-Continuum™
- Automated fixture ready

### MAC Series - Miller/APT/CRX

MAC Cart .....	4
MAC Side Carts .....	4
MAC Accessories .....	6
MAC Traveler.....	8
MAC Bundle .....	9

### MATE Series - Miller/APT/ARC Mate

Single Station Fixed Wide Table.....	10
Dual Station Fixed Table .....	12
Single Station Tilt Table .....	14
Dual Station Rotary Table.....	16
Dual Station Shuttle.....	18

### Other Features & Options

MATE Operator Interface .....	20
Welding Fixtures .....	21



# ROBOT MAC CART

## COLLABORATIVE ROBOT FOR ARC WELDING

The MOD-WELD is designed and manufactured around the FANUC CRX-10iA/L industrial collaborative robot. The CRX models come from a long line of reliable FANUC products that are extremely easy to setup, program, and operate – even if it's your first robot.

The system includes the Miller Auto-Continuum™. The new power source is a smart and powerful digital design, it has the fast response needed to deliver the most stable welding performance for better welding results.

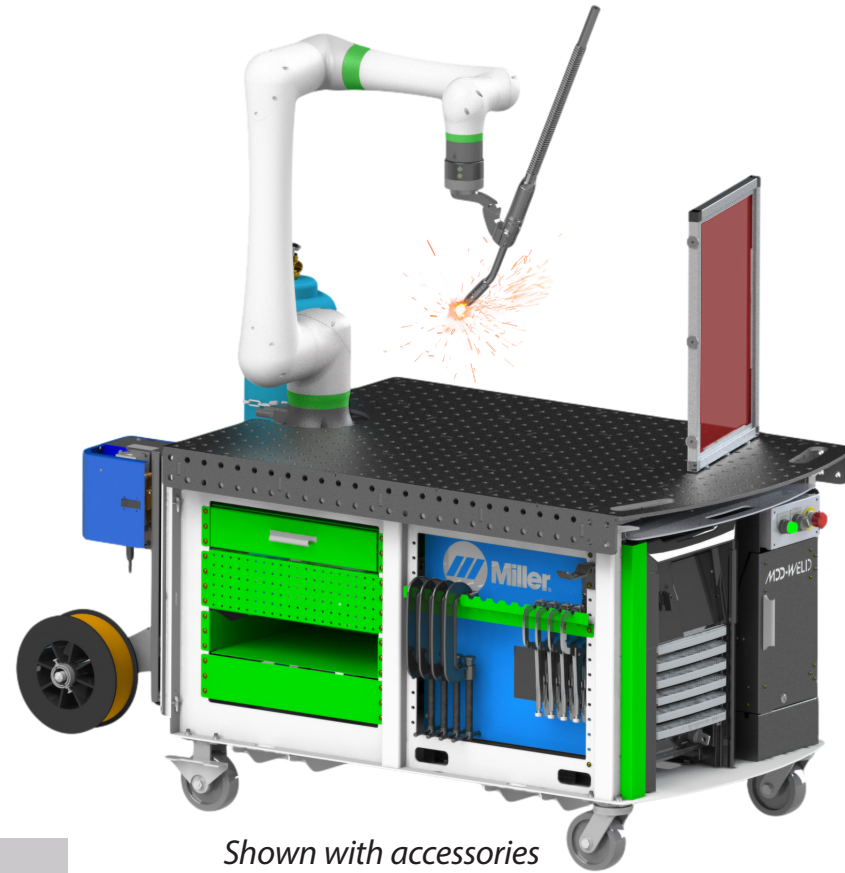

Shown with accessories

## Customize to your needs

Add up to 4 side carts in different configurations for customizing your work space.

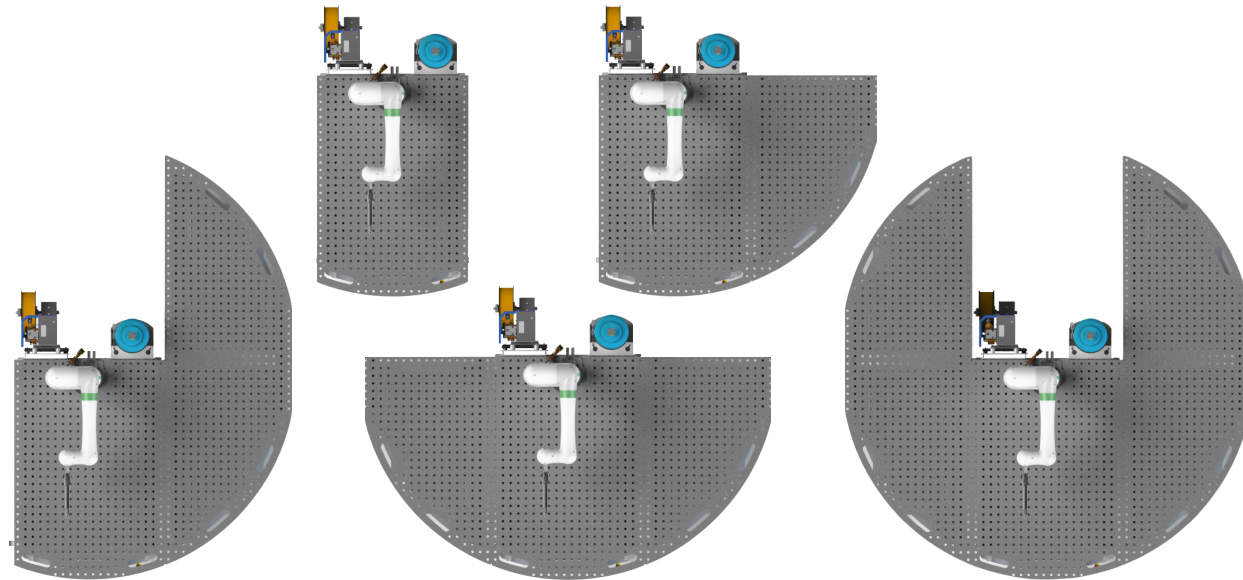

# MOD-WELD

## FEATURES & SPECS

MAC Cart	
Model	CART10L-350
6-Axis Robot	FANUC CRX-10iA/L
Miller Power Source	Auto-Continuum™ 350
Welding material type	<a href="http://millerwelds.com/technologies/advanced-welding-processes">millerwelds.com/technologies/advanced-welding-processes</a>
Footprint	40"W x 78" D
Payload	10kg
Table Work Space	40"W x 58-1/2" D
Clever Torch Teach Guidance	✓
Miller Hand Torch Option	✓
Robot Programming	Tablet Only
FANUC Robot reach	55"
Power Needed FANUC	110v 20 amp
Power Needed Miller	230-575 V 3-phase, 50/60 Hz
Holes for Fixture Clamps	2" x 2" Hole Pattern 16mm Dia
Main Welder Weight	Approximately 1300 lbs
Custom Weld Fixture	✓

MAC Cart - Accessories and Options	
Part #	Part Description
SCLFRR	Side Cart Left Front or Right Rear. Work space 34 3/8" W x 54" D with 16mm holes
SCRFLR	Side Cart Right Front or Left Rear. Work space 34 3/8" W x 54" D with 16mm holes
500	Miller Auto-Continuum™ 500. Replaces the Auto-Continuum™ 350

FANUC's collaborative robots are easy to teach and deploy, which puts them at the forefront of the industry for welding application efficiency. This makes them the perfect fit for high-mix, low-volume production while maintaining high quality welds.

# MAC CART ACCESSORIES

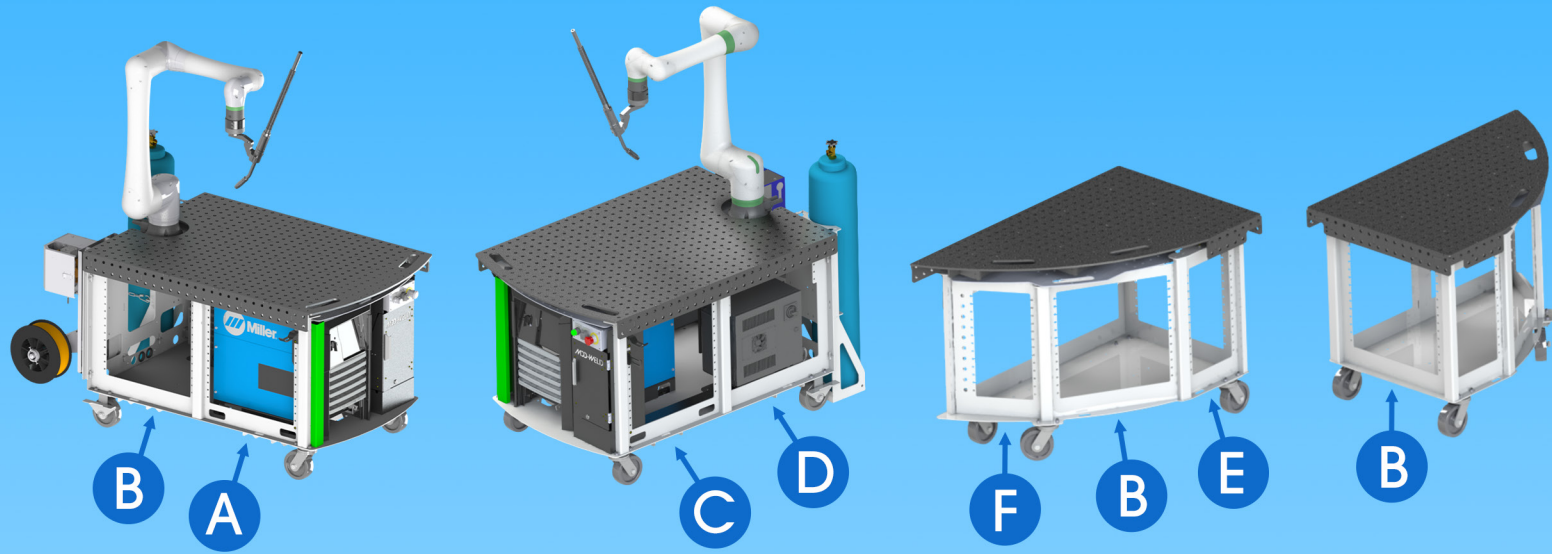

MAC Cart - Accessories			
Image	Part #	Description	Location
	AGHG45	4-1/2" Angle grinder hanger with cord wrap	A, B, C, E, F
	BINP10	Bin box panel, 2 bins (4-1/8"x5-3/8"x3"), narrow	E, F
	BINP20	Bin box panel, 4 bins (4-1/8"x5-3/8"x3"), wide	A, B, C, D
	BP1045	Blanking close out plate, 4-1/2" tall, narrow	E, F
	BP2045	Blanking close out plate, 4-1/2" tall, wide	A, B, C, D
	CR1007	Clamp hanger rail, 7 notches, narrow	E, F
	CR2013	Clamp hanger rail, 13 notches, wide	A, B, C

MAC Cart - Accessories			
Image	Part #	Description	Location
	DIVS10	Drawer divider set for narrow drawers	DW1025, DW1040
	DIVS20	Drawer divider set for wide drawers	DW2025, DW2040
	DW1025	Shallow drawer, 2-1/2" deep, narrow	E
	DW1040	Medium drawer, 4" deep, narrow	E
	DW2025	Shallow drawer, 2-1/2" deep, wide	B, D
	DW2040	Medium drawer, 4" deep, wide	B, D
	PB1006	Pegboard panel, 6" tall, narrow	E, F
	PB2006	Pegboard panel, 6" tall, wide	A, B
	PR1021	Fixture setup pin rail, 21 places, narrow	E, F
	PR2045	Fixture setup pin rail, 45 places, wide	A, B, C, D
	SCSH10	Spray can shallow shelf, narrow	E, F
	SCSH20	Spray can shallow shelf, wide	A, B, C, D
	SH1025	Storage shelf, narrow	E
	SH2025	Storage shelf, wide	B, D
	WS1826	Tabletop temporary weld screen, 18" x 26"	Tabletop

# COBOT MAC TRAVELER

MAC Traveler	
Model	<b>TRAVELER-MW25-350</b>
6-Axis Robot	FANUC CRX-25iA
Miller Power Source	Auto-Continuum™ 350
Welding material type	<a href="http://millerwelds.com/technologies/advanced-welding-processes">millerwelds.com/technologies/advanced-welding-processes</a>
Footprint (for Mobility)	40"W x 76"L
Footprint (outriggers deployed)	89"W x 95"L
CleverTorch Teach Guidance	✓
Miller Hand Torch Option	✓
Robot Programming	Tablet Only
FANUC Robot reach	74"
Power Needed FANUC	110v 20 amp
Power Needed Miller	230-575 V 3-phase, 50/60 Hz
Weight	1,700 lbs approx.
Custom Weld Fixture	✓



MAC Traveler - Options	
Part #	Part Description
500	Miller Auto-Continuum™ 500. Replaces the Auto-Continuum™ 350
COOLER	Miller Continuum™ Cooler and water-cooled torch. Replaces the standard air cooled torch
SRVT	Servo Torch Gun - FANUC option for pulling soft wire. Replaces the Miller Wire Feeder
HWST	Heavy Weld Seam Track - FANUC Touch Sense and Multi Pass Software. Allows the robot path to automatically correct for part variation or out of location parts.
CTRM	Collaborative Tip Reamer. Allows the user to program in cycles to automatically clean the weld

# COBOT MAC BUNDLE



MAC Bundle	
Model	<b>CART10L-350</b>
6-Axis Robot	FANUC CRX-10iA/L
Miller Power Source	Auto-Continuum™ 350
Welding material type	<a href="http://millerwelds.com/technologies/advanced-welding-processes">millerwelds.com/technologies/advanced-welding-processes</a>
Payload	10kg
Clever Torch Teach Guidance	✓
Miller Hand Torch Option	✓
Robot Programming	Tablet Only
FANUC Robot reach	55"
Power Needed FANUC	110v 20 amp
Power Needed Miller	230-575 V 3-phase, 50/60 Hz

**FANUC CRX10iA/L with Miller Auto-Continuum™ 350, Miller wire feeder, and torch for end user addition to table. The Cobot has a reach of 1,418mm (55.8 in) and a payload of 10kg.**

# ROBOT ARC MATE CELL

## SINGLE STATION FIXED WIDE TABLE

# MOD-WELD

## FEATURES & SPECS

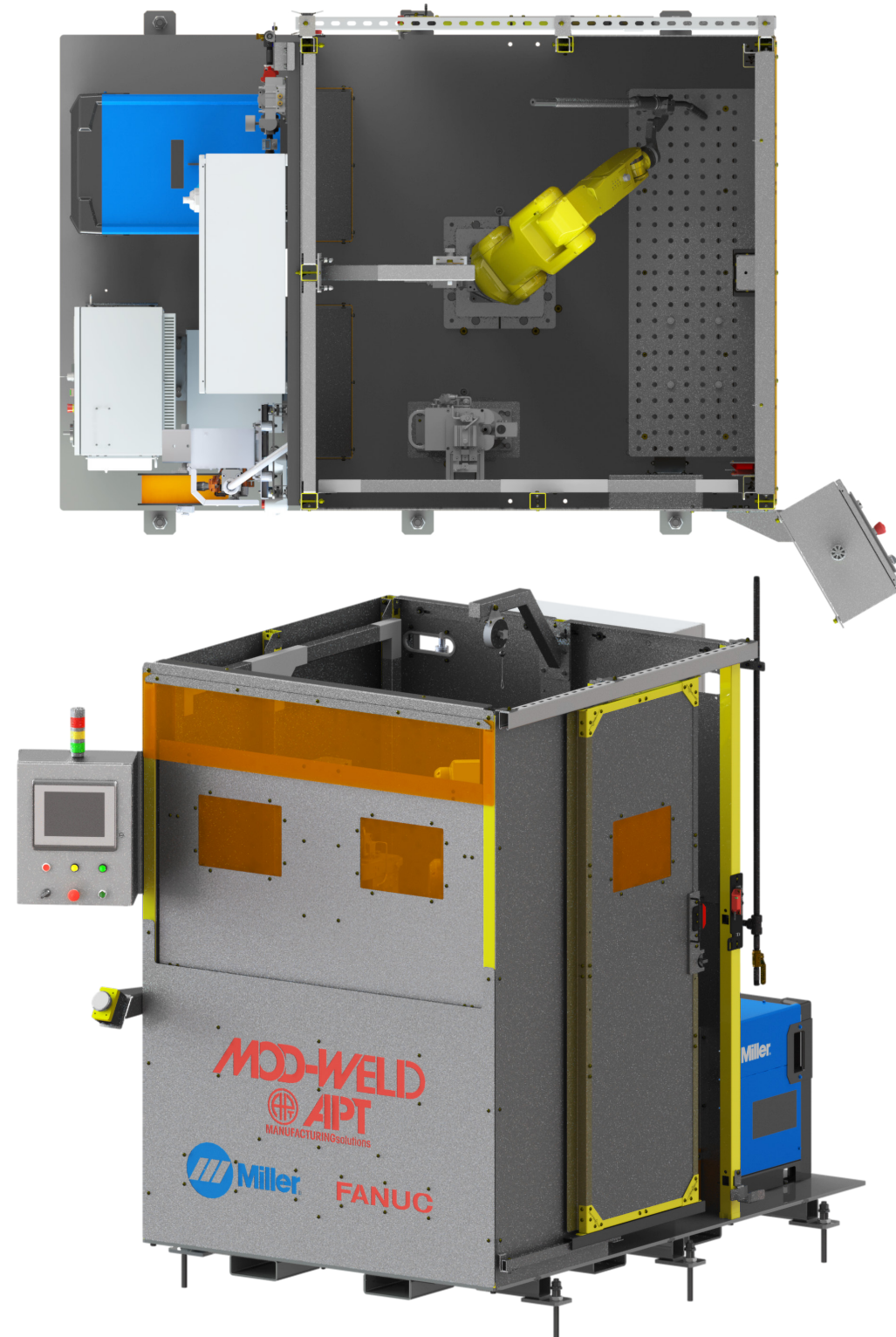

MATE - Single Station Fixed Wide Table			
Model	SSFWT-48-AM50	SSFWT-72-AM100	SSFWT-96-AM120
6-axis robot	FANUC ARC Mate 50iD	FANUC ARC Mate 100iD	FANUC ARC Mate 120iD
Miller power source	Auto-Continuum™ 350	Auto-Continuum™ 350	Auto-Continuum™ 350
Welding material type	<a href="http://millerwelds.com/technologies/advanced-welding-processes">millerwelds.com/technologies/advanced-welding-processes</a>		
Footprint	60" x 90"	84" x 102"	108" x 114"
Power needed	480VAC 3-Phase 60 AMP	480VAC 3-Phase 60 AMP	480VAC 3-Phase 60 AMP
Table size	24" x 48"	36" x 72"	48" x 96"
Available I/O	8 In 8 Out	8 In 8 Out	8 In 8 Out
Available valve bank space	4 closed-center valves and 4 blanks	4 closed-center valves and 4 blanks	4 closed-center valves and 4 blanks
Enclosed cell	✓	✓	✓
Crane accessible	X	X	X

MATE - Accessories	
Part #	Part Description
ABIO-8	Additional Allen Bradley I/O, 8 in 8 out
SY7301-5U1-NA	Additional 3 position closed center valve
500	Miller Auto-Continuum™ 500. Replaces the Auto-Continuum™ 350
MW-48-EX-HOOD	48" Exhaust Hood with 8" duct
MW-72-EX-HOOD	72" Exhaust Hood with 8" duct
MW-96-EX-HOOD	96" Exhaust Hood with 8" duct
RANC	Robotic auto nozzle cleaner, wire cut, spatter removal, and spatter spray

The fixed table allows the operator to load the parts directly into their fixture as the robot waits in a safe position for the safety door to close before welding.

# ROBOT ARC MATE CELL

## DUAL STATION FIXED TABLE

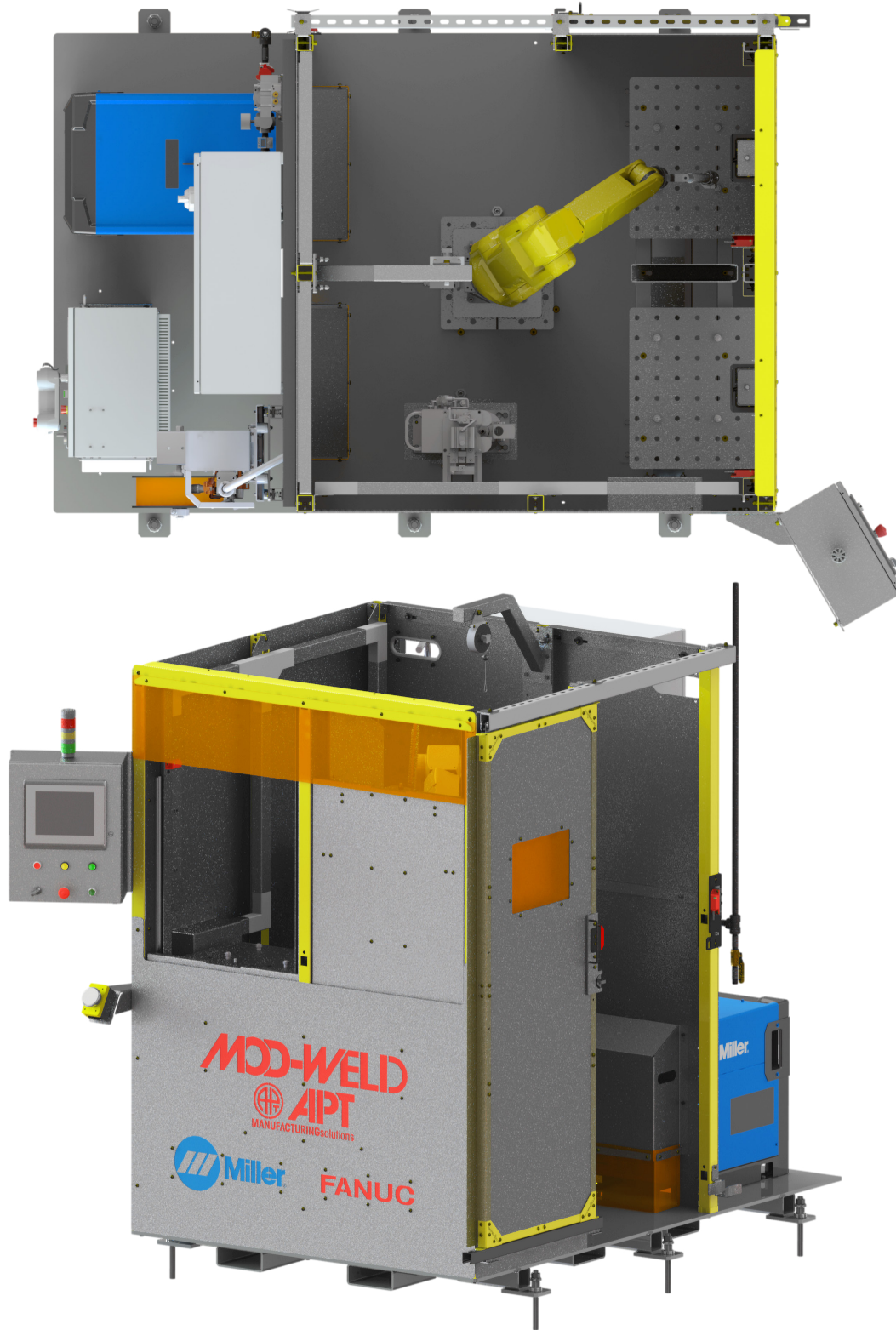

# MOD-WELD

## FEATURES & SPECS

MATE - Dual Station Fixed Table			
Model	DSFT-48-AM50	DSFT-72-AM100	DSFT-96-AM120
6-axis robot	FANUC ARC Mate 50iD	FANUC ARC Mate 100iD	FANUC ARC Mate 120iD
Miller power source	Auto-Continuum™ 350	Auto-Continuum™ 350	Auto-Continuum™ 350
Welding material type	<a href="http://millerwelds.com/technologies/advanced-welding-processes">millerwelds.com/technologies/advanced-welding-processes</a>		
Footprint	60" x 90"	84" x 102"	108" x 114"
Power Needed	480VAC 3-Phase 60 AMP	480VAC 3-Phase 60 AMP	480VAC 3-Phase 60 AMP
Table Size	2 @ 16" x 20"	2 @ 28" x 32"	2 @ 40" x 44"
Available I/O	8 In 8 Out	8 In 8 Out	8 In 8 Out
Available valve bank space	4 closed-center valves and 4 blanks	4 closed-center valves and 4 blanks	4 closed-center valves and 4 blanks
Enclosed cell	✓	✓	✓
Crane accessible	X	X	X

MATE - Accessories	
Part #	Part Description
ABIO-8	Additional Allen Bradley I/O, 8 in 8 out
SY7301-5U1-NA	Additional 3 position closed center valve
500	Miller Auto-Continuum™ 500. Replaces the Auto-Continuum™ 350
MW-48-EX-HOOD	48" Exhaust Hood with 8" duct
MW-72-EX-HOOD	72" Exhaust Hood with 8" duct
MW-96-EX-HOOD	96" Exhaust Hood with 8" duct
RANC	Robotic auto nozzle cleaner, wire cut, spatter removal, and spatter spray

The dual station fixed table allows the operator to load/unload on one fixture while the robot is safely welding on the other side.

# ROBOT ARC MATE CELL

## SINGLE STATION TILT TABLE

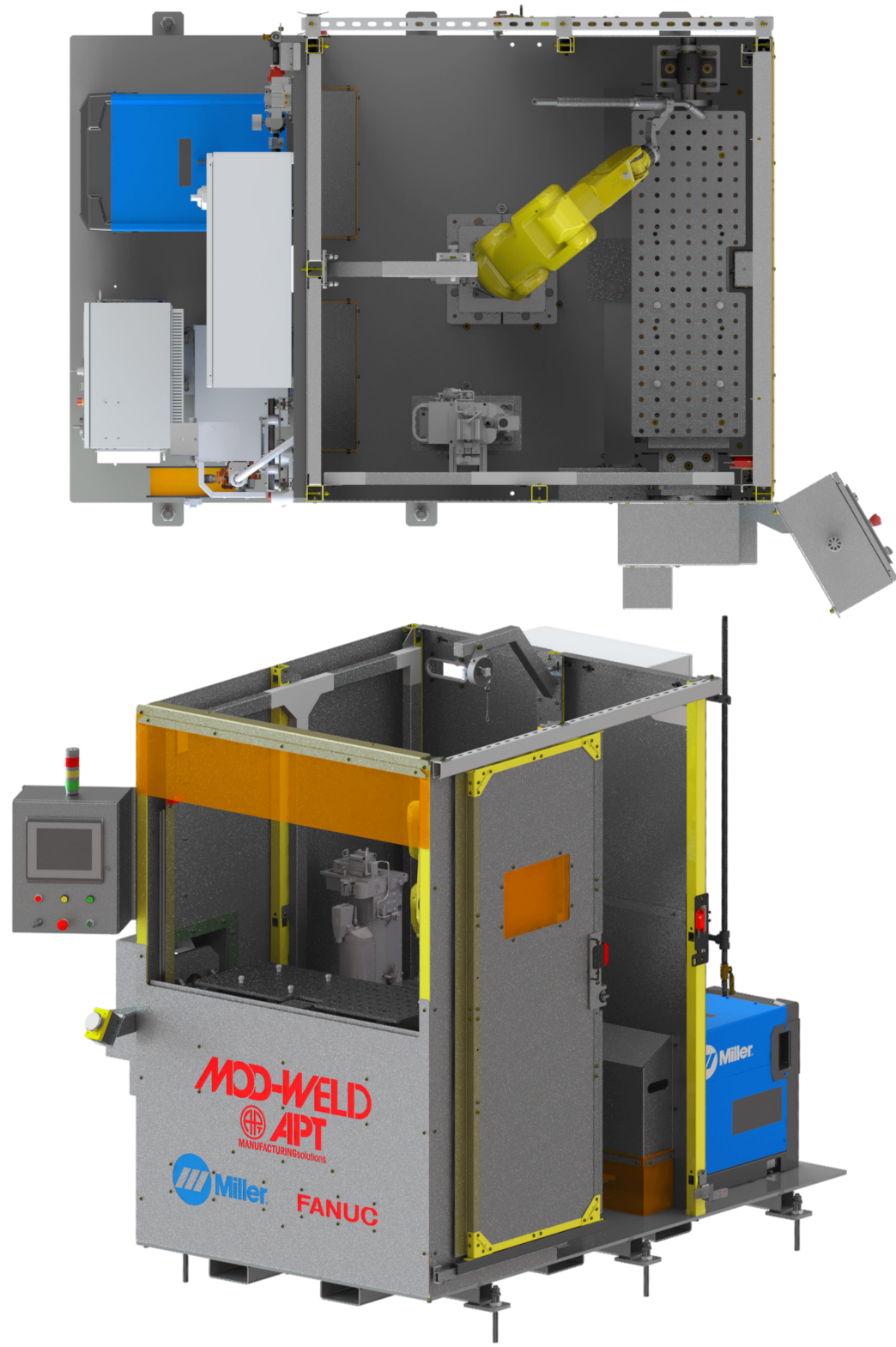

# MOD-WELD

## FEATURES & SPECS

MATE - Single Station Tilt Table			
Model	SSAWT-48-AM50	SSAWT-72-AM100	SSAWT-96-AM120
6-axis robot	FANUC ARC Mate 50iD	FANUC ARC Mate 100iD	FANUC ARC Mate 120iD
Miller power source	Auto-Continuum™ 350	Auto-Continuum™ 350	Auto-Continuum™ 350
Welding material type	<a href="http://millerwelds.com/technologies/advanced-welding-processes">millerwelds.com/technologies/advanced-welding-processes</a>		
Footprint	60" x 90"	84" x 102"	108" x 114"
Power needed	480VAC 3-Phase 60 AMP	480VAC 3-Phase 60 AMP	480VAC 3-Phase 60 AMP
Table size	15" x 42"	27" x 66"	39" x 90"
Available I/O	8 In 8 Out	8 In 8 Out	8 In 8 Out
Available valve bank space	4 closed-center valves and 4 blanks	4 closed-center valves and 4 blanks	4 closed-center valves and 4 blanks
Enclosed cell	✓	✓	✓
Crane accessible	X	X	X

MATE - Accessories	
Part #	Part Description
ABIO-8	Additional Allen Bradley I/O, 8 in 8 out
SY7301-5U1-NA	Additional 3 position closed center valve
500	Miller Auto-Continuum™ 500. Replaces the Auto-Continuum™ 350
MW-48-EX-HOOD	48" Exhaust Hood with 8" duct
MW-72-EX-HOOD	72" Exhaust Hood with 8" duct
MW-96-EX-HOOD	96" Exhaust Hood with 8" duct
RANC	Robotic auto nozzle cleaner, wire cut, spatter removal, and spatter spray

**A fixed wide table with a FANUC Aux Axis added to rotate the fixture into the robot for ease of welding on the back side.**



# ROBOT ARC MATE CELL

## DUAL STATION ROTARY TABLE

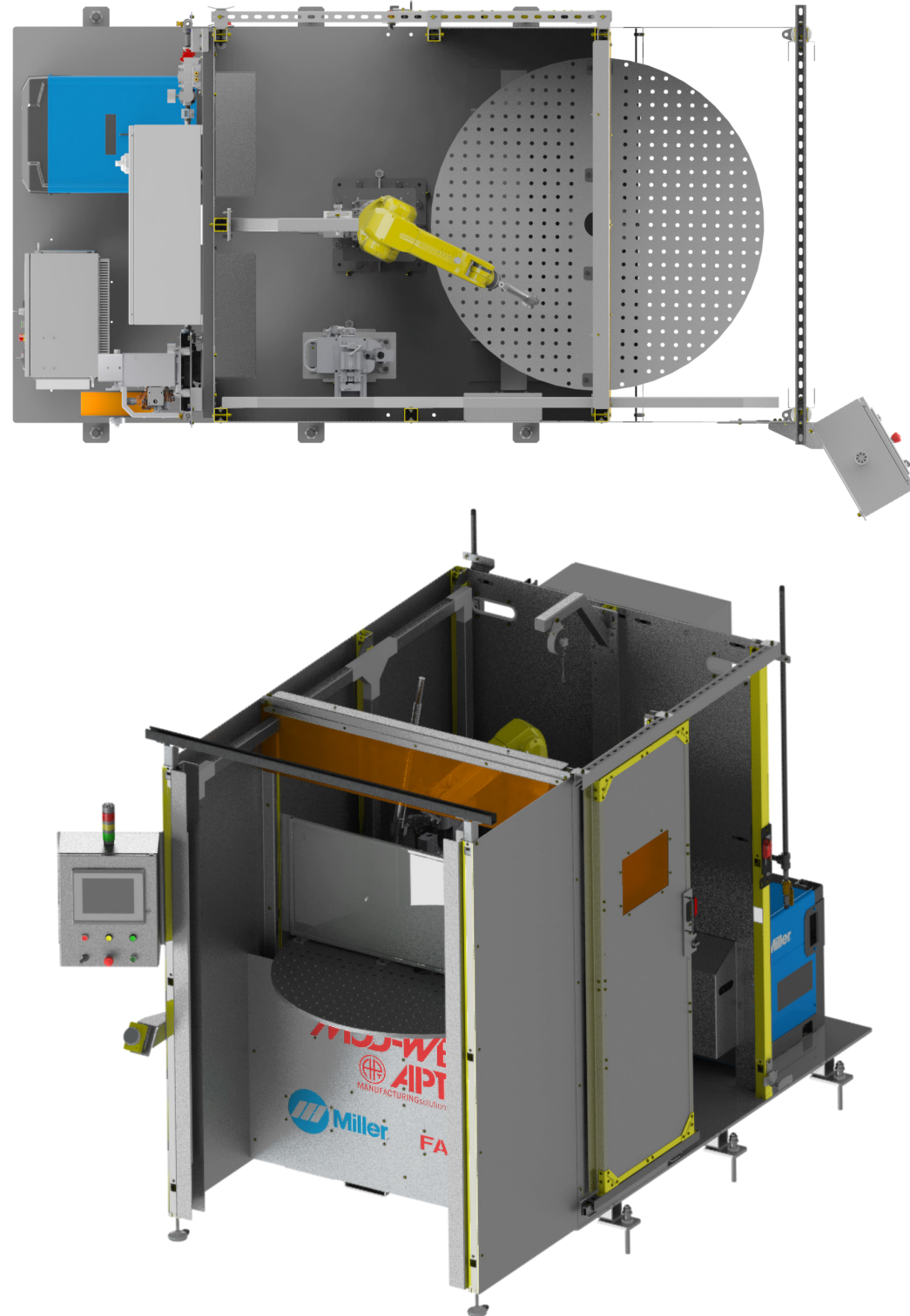

# MOD-WELD

## FEATURES & SPECS

MATE - Dual Station Rotary Table			
Model	DSRT-48-AM50	DSRT-72-AM100	DSRT-96-AM120
6-axis robot	FANUC ARC Mate 50iD	FANUC ARC Mate 100iD	FANUC ARC Mate 120iD
Miller power source	Auto-Continuum™ 350	Auto-Continuum™ 350	Auto-Continuum™ 350
Welding material type	<a href="http://millerwelds.com/technologies/advanced-welding-processes">millerwelds.com/technologies/advanced-welding-processes</a>		
Footprint	60" x 120"	84" x 144"	108" x 168"
Power needed	480VAC 3-Phase 60 AMP	480VAC 3-Phase 60 AMP	480VAC 3-Phase 60 AMP
Table size	Auto Index Ø 48"	Auto Index Ø 72"	Auto Index Ø 96"
Available I/O	8 In 8 Out	8 In 8 Out	8 In 8 Out
Available valve bank space	4 closed-center valves and 4 blanks	4 closed-center valves and 4 blanks	4 closed-center valves and 4 blanks
Enclosed cell	✓	✓	✓
Crane accessible	✓	✓	✓

MATE - Accessories	
Part #	Part Description
ABIO-8	Additional Allen Bradley I/O, 8 in 8 out
SY7301-5U1-NA	Additional 3 position closed center valve
500	Miller Auto-Continuum™ 500. Replaces the Auto-Continuum™ 350
MW-48-EX-HOOD	48" Exhaust Hood with 8" duct
MW-72-EX-HOOD	72" Exhaust Hood with 8" duct
MW-96-EX-HOOD	96" Exhaust Hood with 8" duct
RANC	Robotic auto nozzle cleaner, wire cut, spatter removal, and spatter spray

The rotary table allows the operator to load/unload the product outside of the weld cell, then the rotary table will bring the product into the cell for welding. When the robot has completed the welds on side "A" it will rotate table and begin welding side "B"

# ROBOT ARC MATE CELL

## DUAL STATION SHUTTLE

# MOD-WELD

## FEATURES & SPECS

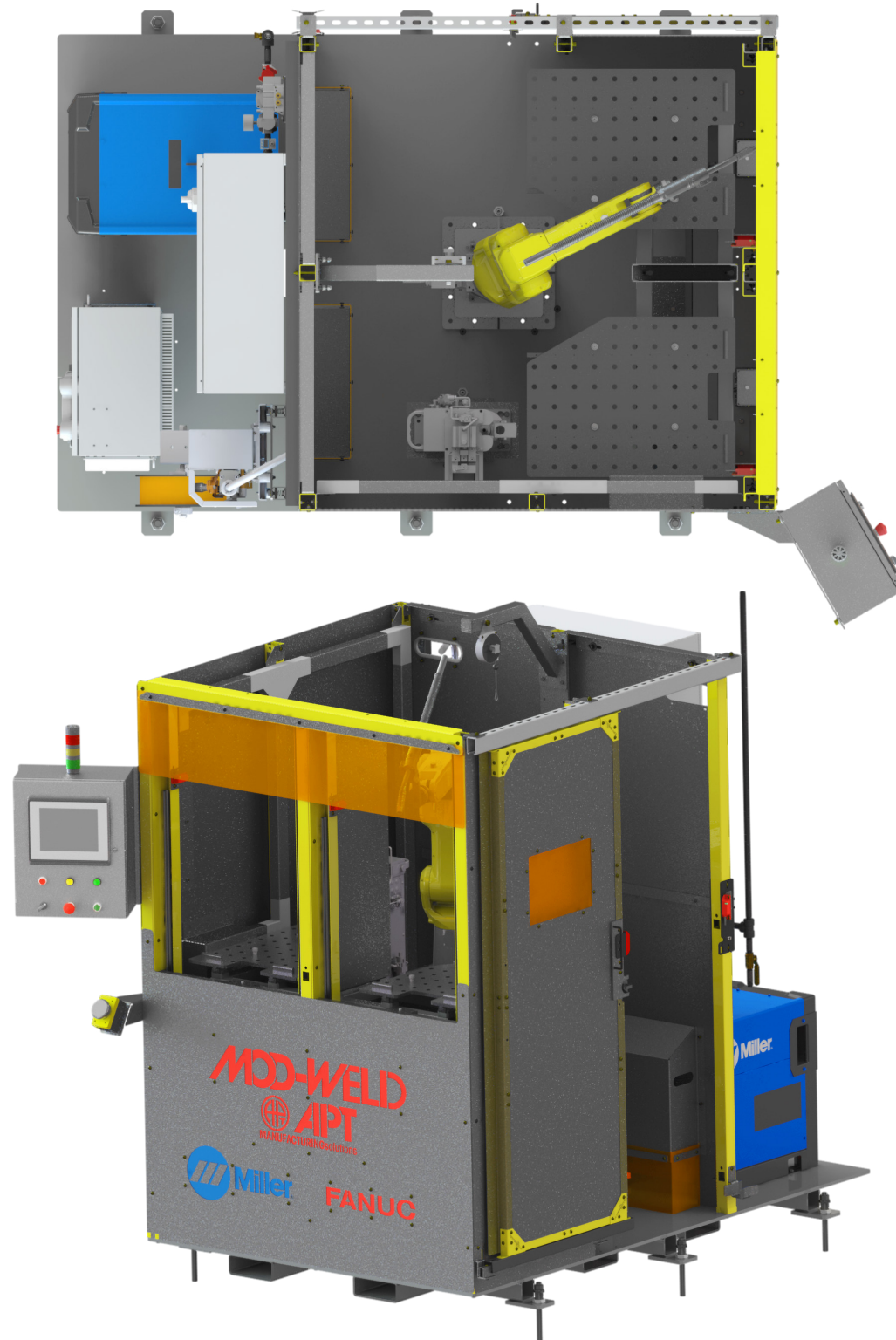

MATE - Dual Station Shuttle			
Model	DSS-48-AM50	DSS-72-AM100	DSS-96-AM120
6-axis robot	FANUC ARC Mate 50iD	FANUC ARC Mate 100iD	FANUC ARC Mate 120iD
Miller power source	Auto-Continuum™ 350	Auto-Continuum™ 350	Auto-Continuum™ 350
Welding material type	<a href="http://millerwelds.com/technologies/advanced-welding-processes">millerwelds.com/technologies/advanced-welding-processes</a>		
Footprint	60" x 90"	84" x 102"	108" x 114"
Power needed	480VAC 3-Phase 60 AMP	480VAC 3-Phase 60 AMP	480VAC 3-Phase 60 AMP
Table size	2 @ 20" x 26"	2 @ 32" x 38"	2 @ 44" x 50"
Available I/O	8 In 8 Out	8 In 8 Out	8 In 8 Out
Available valve bank space	4 closed-center valves and 4 blanks	4 closed-center valves and 4 blanks	4 closed-center valves and 4 blanks
Enclosed cell	✓	✓	✓
Crane accessible	✓	✓	✓

MATE - Accessories	
Part #	Part Description
ABIO-8	Additional Allen Bradley I/O, 8 in 8 out
SY7301-5U1-NA	Additional 3 position closed center valve
500	Miller Auto-Continuum™ 500. Replaces the Auto-Continuum™ 350
MW-48-EX-HOOD	48" Exhaust Hood with 8" duct
MW-72-EX-HOOD	72" Exhaust Hood with 8" duct
MW-96-EX-HOOD	96" Exhaust Hood with 8" duct
RANC	Robotic auto nozzle cleaner, wire cut, spatter removal, and spatter spray

The shuttle system allows the operator to load/unload the product outside of the weld cell, then the auto shuttle will bring the product into the cell for welding. When the robot has completed the welds on shuttle "A" it will shuttle that fixture out and begin welding on shuttle "B"

# MATE OPERATOR INTERFACE

The Rockwell controls integration on the MOD-WELD MATE series was designed with the end user in mind. The operator interface is easy-to-use, has fewer HMI control touch points, visual factory concepts & simplified maintenance and troubleshooting.

**SYSTEM** - These screens are used for general machine setup. A majority of the functions available have security requirements to access them. Some Functions on the System HMI screens include: VFD frequency setup, Recipe Management System, Inspection Limits, I/O Link Setup, Login, and System Security Settings.

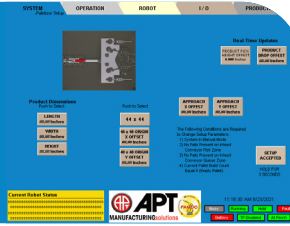

**OPERATION** - These screens are used for general machine operation and functionality. 3D model images are shown on the screen for ease of use. Status Indicators, Mode Control, and Manual Operations, along with Operational and Fault Messages, are displayed on these screens.



**ROBOT** - This screen displays all communication and I/O interface between the system PLC and robot. Users may also manually control the functions of the robot and call a specific robot program to run from this screen.

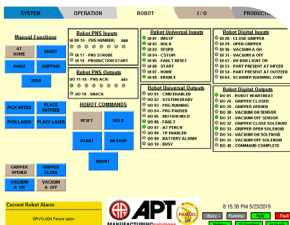

**I/O** - On this screen users can see all I/O within the system, its present status on/off to run diagnostics and aid in troubleshooting.



**PRODUCTION** - From these screens the user can view and capture production data to be used for business analytics. Recipe management and the production scheduler allow the users to edit the parameters and schedule all products the system can run.

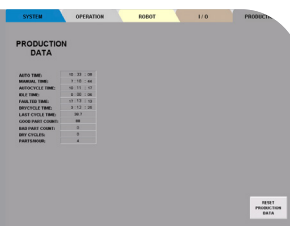

## CONTROLS MADE SIMPLE WITH VISUAL FACTORY CONCEPTS

- The most accurate and efficient information conveyance
- 5 standard HMI screens with enhanced diagnostics
- Quick changeovers
- Simple recipe storage; easily selectable and expandable
- Password-protected levels
- Engineered with perfection

# MOD-WELD WELDING FIXTURES

## HAND CLAMP & AUTOMATED

APT offers a select design service with our inhouse engineering team. Their many years of experience will provide specific fixture solutions for accuracy and repeatability.

Please contact your distributor for pricing of welding fixture solutions.

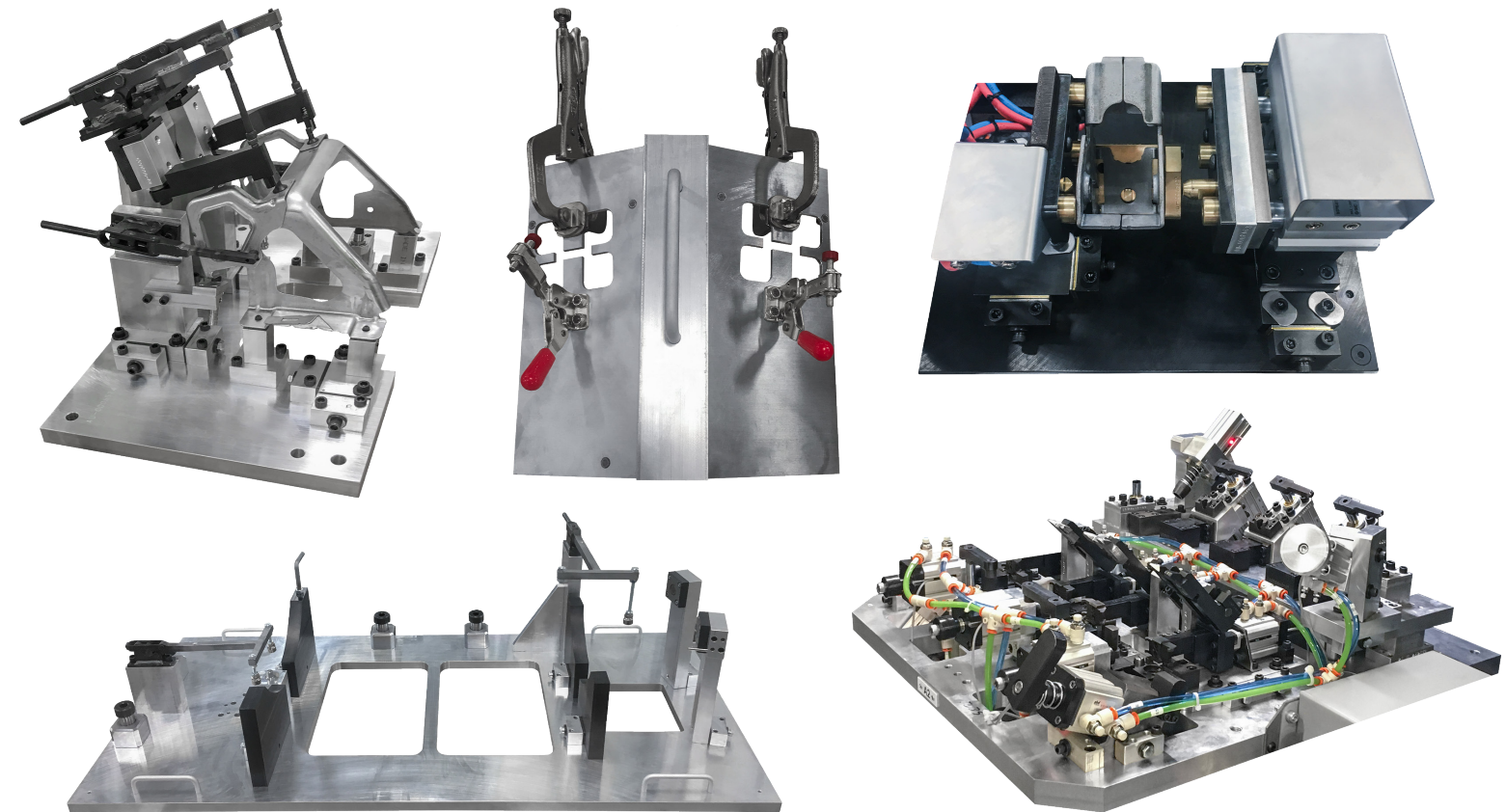

- Hardened Contact Points
- Adjustability of Locating Materials
- Veteran Design Team
- MIC 6 aluminum baseplates for light weight.
- Aluminum bronze wear details to prevent spatter from sticking.
- NAAMS style shims for adjustability of locating details.
- Part presence sensors (as required per application)
- Concept approval drawing and 3D pdf provided upon purchase and your CAD data

NOTES: \_\_\_\_\_

---

---

---

---

---

---

---

---

---

---

---

---

---

---

---

---

---

---

---

---

---

---

---

NOTES: \_\_\_\_\_

---

---

---

---

---

---

---

---

---

---

---

---

---

---

---

---

---

---

---

---

---

---

---



# FANUC



March 2023

For more information visit:  
[aptmfg.com/welding](http://aptmfg.com/welding)